



Heraeus Noblelight LightHammer® Mark III System Introducing the New Heraeus Intelligent Irradiator...

Further building upon our latest, most technologically advanced smart power supply platform, the LightHammer® Mark II, numerous sensors are now integrated into the Irradiator to make the Intelligent Irradiator. Heraeus Noblelight's new Intelligent Irradiator is part of the **LightHammer® Mark III System**; making an industry first, complete Smart UV Curing System. The LightHammer® Mark III is IoT-enabled for today's and the future's Digitization Roadmap.

With intelligence now added to the Irradiator, the irradiator operating parameters can be measured and monitored remotely. The data obtained from the new sensors is sent to the associated LightHammer® Mark III power supply via a CAN communication. The entirety of this data can be viewed using the optional Heraeus monitoring software, Advanced Integrated Monitoring System (AIMS Cloud), now available for the LightHammer® Mark III Systems. This software application provides real-time system performance monitoring, enhanced system diagnostics, and preventative maintenance capability. Through the use of a

proprietary communication network, many of the Smart UV Curing System's critical performance metrics can now be measured and monitored by a PC connected to the unit's network.

Key Features

- New sensors added to measure relative UV intensity, irradiator air pressure, inlet air temperature, bulb temperature, magnetron temperatures, ambient temperature, air humidity, and irradiator orientation.
- System parameters can be monitored via the optional Advanced Integrated Monitoring System (AIMS Cloud).
- Provides accurate, real-time data to improve total cost of ownership, increase equipment and production up-times, increase operational intelligence, and improve system efficiency and reliability.
- Data can be used for system performance monitoring, system diagnostics and predictive maintenance, and much, much more.
- Intelligent Irradiator has same form and fit of existing LHI10 Mark II irradiators and can be a direct replacement for an existing Mark II irradiator.

Specifications: LH10 Mark III System

LHI10 Mark III Intelligent Irradiator

- Weight:** LHI10 Mark III: 19 kg (42 lbs.).
LHI10B Mark III: 28 kg (61 lbs.).
- Dimensions:** LHI10 Mark III: 267 mm (10.5 in.) long x 208 mm (8.2 in.) wide at base x 384 mm (15.13 in.) high;
LHI10B Mark III: 267 mm (10.5 in.)

long x 313 mm (12.32 in.) wide at blower top x 662 mm (26.07 in.) high.

- Cooling:** 7.7 m³/min. @ 2,500 Pa (270 scfm @ 10.0 in. H₂O) to 8.9 m³/min. @ 3,125 Pa (315 scfm @ 12.5 in. H₂O).

Mounting Position: Any orientation.

Operating Voltage: Powered through LHI10 Mark III power supply.

Substrate Location: 53 mm (2.1 in.) from face of lamp for maximum irradiance.

Footprint: 266.7 mm x 200 mm (10.5 in. x 7.87 in.).

Bulb Fills: D, H, H+, M, Q, and V.

Magnetron Output @100% Power: 240 W/cm (600 W/in.).

Sensors: Relative UV output, bulb temperature, analog air pressure, and others.

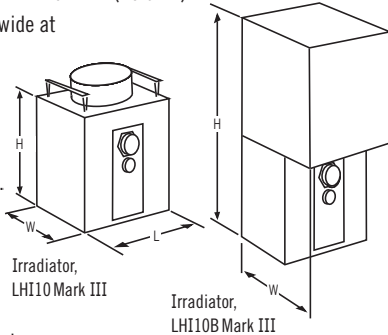

Intelligence Inside

- | | | |
|--|--|---|
| <ul style="list-style-type: none"> ■ UV Sensor ■ Bulb Temp Sensor ■ Mag A Temp Sensor ■ Mag B Temp Sensor ■ Inlet Air Temp Sensor | | <p style="text-align: center;">Main Board</p> <ul style="list-style-type: none"> ■ Orientation Sensor ■ Analog Pressure Sensor ■ Ambient Temp Sensor ■ Humidity Sensor |
|--|--|---|

LH Mark III Power Supply

- Improved/Lower Total Cost of Ownership
- Up to 20+% Energy Savings
- >99% Power Factor Correction
- ~90% High Efficiency
- Minimum Total Harmonic Distortion (THD)
- DC Output w/Essentially No Ripple
- Universal Industrial Input Power, Auto Ranging
- 4 Optional World Leading Industrial Open Communication Protocols
- IoT-Enabled
- Up to 75% Lighter than Ferro-Resonant PS
- Meets and Exceeds World-Wide Standards & Directives
- Backwards Compatible

LHP10 Mark III Power Supply

- Weight:** 25 kg (55 lbs.); 27 kg (60 lbs.) w/ blower control module.
- Dimensions (W x H x L):** 419 mm (16.5 in.) x 217 mm (8.54 in.) x 777 mm (30.6 in.) with connector.
- Cooling:** Internal fans.
- Input Voltages:** 200 V–480 V (auto-ranging), 3-phase, 50/60 Hz.
- Max Line Current:** At 380–480 V: 11.3–15 A, at 200–240 V: 23.5–28.6 A.
- Mounting Position:** Horizontal – unit can be free standing, stacked, or rack mounted.
- Line Power at 100%:** 10 kVA.
- Clearance:** Allow 305 mm (12 in.) clearance front and rear of the power supply for cooling air flow and cable connections.
- Safety Interlocks:** E-stop, external interlocks (customer I/O), RF fault.
- Mag Current @ 100% Power:** 890 mA/magnetron.
- Mag Current Output Accuracy:** ±1%.
- Power Factor @ 100% power:** 99%.
- I/O Communications:** ⁽¹⁾Master/Slave (dry contact)(S), DeviceNet™ (O), Profibus® (O), EtherNet/IP™ (O), Profinet® (O).
- ⁽¹⁾**Power Level Control:** 4–20 mA, 0–10 vdc, 4-bit binary, front panel.
- Front Panel Indicators/Controls:** Power On/Off switch, USB port, display unit with ON/Standby/OFF buttons and Power Level control buttons.

Specifications subject to change without notice.

⁽¹⁾ LH10 Mark III Power Supply Power Level Control Options

Method	Control
4–20 mA input	1% steps, via master/slave operation
0–10 Vdc input	1% steps, via master/slave operation
4-bit binary input	5% steps, via master/slave operation
front panel switches	1% steps, via master/slave operation

Contact your local Heraeus Noblelight office for an engineered solution for your specific requirements.

ISO 9001 Certified QMS



<p>Germany Heraeus Noblelight GmbH Heraeusstraße 12-14 63450 Hanau Phone +49 6181 35 4499 Fax +49 6181 35 9926 hng-uv@heraeus.com www.heraeus-noblelight.com</p>	<p>USA Heraeus Noblelight America LLC 910 Clopper Road Gaithersburg, Maryland 20878-1357 Phone +1 301 527 2660 Fax +1 301 527 2661 info.hna.uvp@heraeus.com www.heraeus-noblelight.com/uvamericas</p>
---	--

Japan
Heraeus K.K.
Noblelight Division
Sumitomo Fudosan Otowa
Building 1F, 2F, 5F
2-9-3 Otsuka, Bunkyo-ku
112-0012, Tokyo
Phone +81 3 6902 6602
Fax +81 3 6902 6613
info.hkk@heraeus.com
www.heraeus-noblelight.jp

China
Heraeus Noblelight (Shenyang) Ltd.
Shanghai Branch
2F, 5th Building, No. 406 Guilin Rd
Xuhui District
Shanghai 200233, P.R. China
Phone +86 400 080 2255
Fax +86 21 3357 5333
info.hns@heraeus.com
www.heraeus-noblelight.com